

PROTEIN



BAKERY



# PROLEAVER 6100

**pacproinc**  
Pacproinc, LLC

**Experience unmatched performance with ProLeaver® interleavers, designed for precise automation in placing paper under or between food portions.**

The ProLeaver 6100 eliminates the need for manual intervention, boosting production efficiency and ensuring consistent results. Featuring adjustable cut lengths, it delivers precise portioning and robust performance. Its compact design and user-friendly operation optimize production rates, making the ProLeaver 6100 a key investment for your production line.

## FEATURES

- **Infeed-Outfeed Conveyor:** Stepper-controlled paper feed with friction unwind for precise handling.
- **Heated Electrical Enclosure:** Ensures optimal operating conditions and enhances equipment reliability.
- **Standard Construction & Simplified Maintenance:** Durable design with easy maintenance for long-term use.
- **Safety Circuit:** Provides reliable safety measures and ensures operational security.
- **Pro-face™ HMI & Touchscreen PLC:** User-friendly interface for easy operation and control.
- **Infeed Conveyor Sensor:** Detects product placement for precise interleaving.
- **Removable Conveyor Assembly:** Simplifies maintenance and cleaning, reducing downtime.

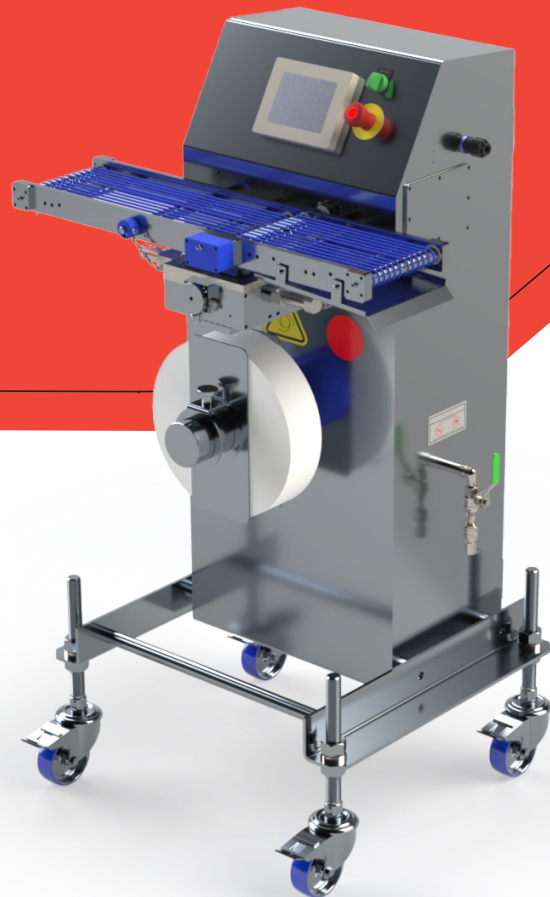

**Elevate your production with the ProLeaver** - where precision meets versatility.

**Scan the QR code for a personalized quote.**



# TECHNICAL SPECIFICATIONS

## Operating Width

6"

## Cut Length

3" minimum  
6" maximum

## Production Rates

Up to 100 portions per minute  
(product dependent)

## Multi-Lane Capability

No

## Utilities

Electrical: 240 VAC, 1 Phase,  
10 amp, 60 Hz  
Pneumatic: 60 PSIG @ 0.5 CFM

## Interleaving Materials

Paper: Uncoated, Wet or dry waxed, Silicone coated, Bakeable

Rollstock: Up to 12" diameter x  
6" wide with a 3" diameter core

## Certifications

Patent Pending



# TECHNICAL DRAWINGS

Top View

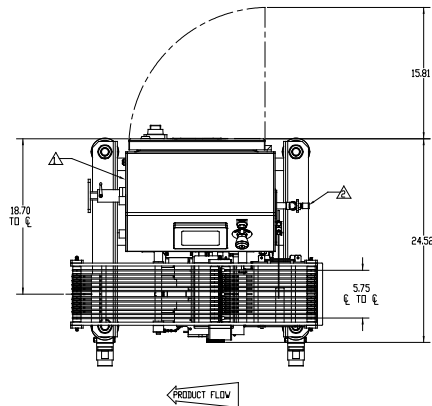

End View

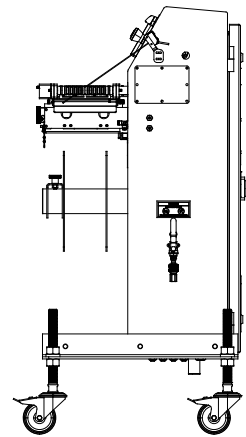

Front View

